

This article was downloaded by:

On: 23 January 2011

Access details: *Access Details: Free Access*

Publisher *Taylor & Francis*

Informa Ltd Registered in England and Wales Registered Number: 1072954 Registered office: Mortimer House, 37-41 Mortimer Street, London W1T 3JH, UK



Journal of Carbohydrate Chemistry

Publication details, including instructions for authors and subscription information:

<http://www.informaworld.com/smpp/title~content=t713617200>

The Structure Of Hexa-*O*-acetyl- α -d-fructofuranose- β -d-fructofuranose 1,2':2,6'-Dianhydride

Merilyn Manley-Harris^a; Brian K. Nicholson^a; Ralph A. Thomson^a

^a Department of Chemistry, University of Waikato, Hamilton, New Zealand

Online publication date: 27 February 2003

To cite this Article Manley-Harris, Merilyn , Nicholson, Brian K. and Thomson, Ralph A.(2003) 'The Structure Of Hexa-*O*-acetyl- α -d-fructofuranose- β -d-fructofuranose 1,2':2,6'-Dianhydride', *Journal of Carbohydrate Chemistry*, 22: 1, 1 – 8

To link to this Article: DOI: 10.1081/CAR-120019009

URL: <http://dx.doi.org/10.1081/CAR-120019009>

PLEASE SCROLL DOWN FOR ARTICLE

Full terms and conditions of use: <http://www.informaworld.com/terms-and-conditions-of-access.pdf>

This article may be used for research, teaching and private study purposes. Any substantial or systematic reproduction, re-distribution, re-selling, loan or sub-licensing, systematic supply or distribution in any form to anyone is expressly forbidden.

The publisher does not give any warranty express or implied or make any representation that the contents will be complete or accurate or up to date. The accuracy of any instructions, formulae and drug doses should be independently verified with primary sources. The publisher shall not be liable for any loss, actions, claims, proceedings, demand or costs or damages whatsoever or howsoever caused arising directly or indirectly in connection with or arising out of the use of this material.



JOURNAL OF CARBOHYDRATE CHEMISTRY

Vol. 22, No. 1, pp. 1–8, 2003

The Structure of Hexa-*O*-acetyl- α -D-fructofuranose- β -D-fructofuranose 1,2':2,6'-Dianhydride

Merilyn Manley-Harris,* Brian K. Nicholson,
and Ralph A. Thomson

Department of Chemistry, University of Waikato, Hamilton, New Zealand

ABSTRACT

The crystal structure of 3,4,6,1',3'4'-hexa-*O*-acetyl- α -D-fructofuranose- β -D-fructofuranose 1,2':2,6'-dianhydride, **1**, has been determined. The central, eight-membered 1,3,6-trioxacane ring is in a twist-boat-chair conformation. Molecular modeling has shown that this conformation is inherent and not due to crystal packing forces and is also the most likely conformation present in underivatized α -D-fructofuranose- β -D-fructofuranose 1,2':2,6'-dianhydride.

Key Words: Difructose dianhydride; Conformation; 1,3,6-trioxacane ring.

INTRODUCTION

α -D-Fructofuranose- β -D-fructofuranose 1,2':2,6'-dianhydride (α -D-Fruf-1,2':2,6'- β -D-Fruf, difructose anhydride V) was characterised by Matsuyama et al.^[1] after isolation from a culture of *Aspergillus fumigatus* grown upon inulin as the sole carbon source. The authors were unable to ascertain the origin of α -D-Fruf-1,2':2,6'- β -D-Fruf since it did not appear during preparation of the culture medium and repeated efforts were unable to isolate the enzyme responsible for its formation.

*Correspondence: Merilyn Manley-Harris, Department of Chemistry, University of Waikato, Private Bag 3105, Hamilton, New Zealand; E-mail: manleyha@waikato.ac.nz.

Subsequently α -D-Fruf-1,2':2,6'- β -D-Fruf, was identified in a mixture of fourteen di-D-fructose dianhydrides formed during thermal treatments of inulin in the presence of citric acid^[2] and the kinetics of formation and disappearance were studied.

We here analyze the crystal structure of per-*O*-acetylated α -D-fructofuranose- β -D-fructofuranose 1,2':2,6'-dianhydride.

EXPERIMENTAL

White crystals of 3,4,6,1',3'4'-hexa-*O*-acetyl- α -D-fructofuranose- β -D-fructofuranose 1,2':2,6'-dianhydride, **1**, prepared as described in Ref. [2], were obtained from chloroform/heptane. Crystal and intensity data were collected on a Bruker P4 diffractometer fitted with a CCD detector.

Crystal data: C₂₄H₃₂O₁₆, M_r 576.50, monoclinic, space group P2₁, a = 9.132(3), b = 11.778(4), c = 12.822(5) Å, β = 99.241(5)°, U 1361.2(9) Å³ T 168 K, D_{calc} = 1.407 g cm⁻³ for Z = 2, F(000) 608, μ (Mo-K α) 0.12 mm⁻¹. Crystal size 0.60 × 0.47 × 0.34 mm³. Total reflections collected 17937, unique data 5529 (R_{int} = 0.0354), 2.2° < θ < 26.4°.

The structure was solved by Direct Methods and refined on F². Absolute structure was assigned based on the known configuration of the molecule. Final R₁ (2 σ data) 0.0341, wR₂ (all data) 0.0706, GoF 1.021, final Δe 0.27/ -0.20 e Å⁻³. All calculations were carried out with the SHELX97 programs.^[3]

Molecular modeling was carried out using the Macromodel v.7 program^[4] on a Silicon Graphics O2 computer. A Monte Carlo search of 500 structures was carried out with the structures minimized using the MM3* force field and water as solvent. The lowest energy structure was used as the starting point for another search of 500 structures to ensure that the minimum energy had been found.

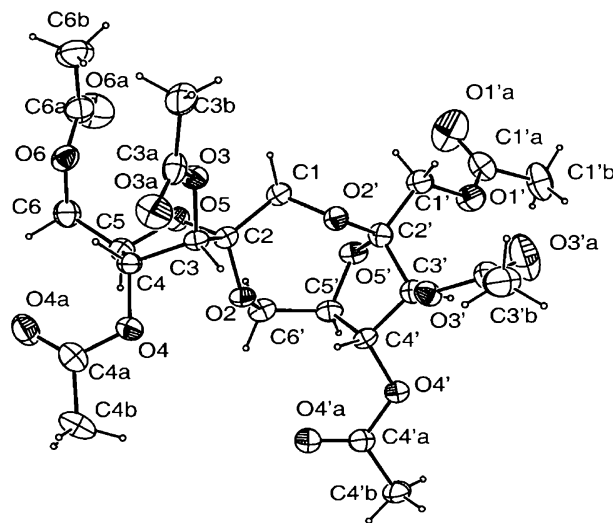

Figure 1. A view of the structure of **1** showing the atom labeling scheme.



RESULTS AND DISCUSSION

The structure of **1** is shown in Figure 1, which also indicates the labelling system; in accordance with the usual convention^[5] the atoms of the 2,6-linked-fructofuranose ring are primed; atoms of *O*-acetyl groups bear the same number as the carbon to which they are attached, the atoms of the carbonyl moiety being designated with a lowercase a and the carbon of the methyl group with a lowercase b. Selected bond angles and lengths are given in Table 1 and torsion angles for the eight-membered and furanose rings are given in Tables 2 and 3, respectively.

1 has the expected three ring structure with the central, eight-membered, 1,3,6-trioxacane ring fused to one furanose ring through a *spiro* carbon at C(2) and to the other furanose ring at C(2') and C(5'). It has been suggested^[2] that the lack of thermal stability of α -D-Fruf-1,2':2,6'- β -D-Fruf compared to other di-D-fructose dianhydrides is likely to be related to the size and shape of the trioxacane ring. Thus the shape of this central ring is of interest.

Calculations for unsubstituted, trioxacane rings^[6] indicate that the lowest energy conformation is the boat-chair (*BC*). However for a 1,3,6-trioxacane ring there are three boat-chair conformations differing in the disposition of the oxygens and of the three

Table 1. Selected bond parameters for **1**.

Bond lengths (Å)			
C(1)–O(2')	1.434(2)	C(1)–C(2)	1.524(3)
C(2)–O(2)	1.408(2)	C(2)–O(5)	1.413(2)
C(2)–C(3)	1.526(2)	O(2)–C(6')	1.434(2)
C(3)–O(3)	1.440(2)	C(3)–C(4)	1.525(3)
C(4)–O(4)	1.446(2)	C(4)–C(5)	1.544(2)
C(5)–O(5)	1.445(2)	C(5)–C(6)	1.499(3)
C(6)–O(6)	1.443(3)	C(1')–O(1')	1.437(2)
C(1')–C(2')	1.512(3)	C(2')–O(5')	1.404(2)
C(2')–O(2')	1.423(2)	C(2')–C(3')	1.527(3)
C(3')–O(3')	1.437(2)	C(3')–C(4')	1.513(3)
C(4')–O(4')	1.453(2)	C(4')–C(5')	1.535(3)
C(5')–O(5')	1.463(2)	C(5')–C(6')	1.508(3)
Bond angles (°)			
O(2')–C(1)–C(2)	109.31(15)	O(2)–C(2)–O(5)	112.18(14)
O(2)–C(2)–C(1)	113.18(16)	O(5)–C(2)–C(1)	107.11(15)
O(2)–C(2)–C(3)	102.54(15)	O(5)–C(2)–C(3)	103.85(15)
C(1)–C(2)–C(3)	117.70(14)	C(2)–O(2)–C(6')	117.29(14)
C(4)–C(3)–C(2)	102.52(14)	C(3)–C(4)–C(5)	104.79(15)
O(5)–C(5)–C(4)	105.20(14)	C(2)–O(5)–C(5)	107.44(14)
O(5')–C(2')–O(2')	112.38(15)	O(5')–C(2')–C(1')	109.71(15)
O(5')–C(2')–C(3')	102.56(15)	O(2')–C(2')–C(3')	107.86(15)
C(2')–O(2')–C(1)	116.94(13)	C(4')–C(3')–C(2')	102.30(15)
C(3')–C(4')–C(5')	104.53(16)	O(5')–C(5')–C(6')	111.42(16)
O(5')–C(5')–C(4')	104.68(14)	C(6')–C(5')–C(4')	114.49(16)
C(2')–O(5')–C(5')	108.50(13)	O(2)–C(6')–C(5')	112.84(14)

**Table 2.** Torsion angles ($^{\circ}$) measured for the eight-membered, 1,3,6-trioxacane ring in **1** compared with values derived by modeling and with calculated values for cyclooctane in the *TBC* conformation.

Angle	Cyclooctane (<i>TBC</i>) ^[11]	Experimental ^a values for 1	Calculated ^b values for 1	Calculated ^b values for underivatized 1
C2–O2–C6'–C5'	93	97	96	86
O2–C6'–C5'–O5'	–88	–80	–81	–79
C6'–C5'–O5'–C2	93	102	105	110
C5'–O5'–C2'–O2'	–51	–76	–79	–70
O5'–C2'–O2'–C1	–45	–31	–32	–34
C2'–O2'–C1–C2	116	112	112	110
O2'–C1–C2–O2	–45	–42	–41	–36
C1–C2–O2–C6'	–52	–61	–62	–66

^aFrom the X-ray structure.^bFrom molecular modeling studies.

only *BC*-1,3,6 is lower in energy than the crown conformation. NMR data has indicated^[7,8] that the boat-chair and another, crown family, conformations are in equilibria. This has been attributed^[6] to solvent effects with the crown conformation being favored by more polar solvents. The only two relevant examples of eight-membered, trioxacane rings, which are derived from carbohydrates and which have previously been characterized by crystallographic data, are 1',2:4,6-di-*O*-isopropylidene-sucrose tetraacetate,^[9] **2**, and methyl-2,3',6-tri-*O*-acetyl-2',3:4',6'-di-*O*-benzylidene-cellobioside,^[10] **3**, which show substituted 1,3,6-trioxacane rings in the *BC*-1,3,6 and

Table 3. Torsion angles ($^{\circ}$) measured for the fructofuranose rings in **1** compared with values derived by molecular modeling of **1** and the underivatized analog of **1**.

Angle	Experimental ^a values for 1	Calculated ^b values for 1	Calculated ^b values for underivatized 1
C2–C3–C4–C5	–19	38	11
C3–C4–C5–O5	–4	–38	–34
C4–C5–O5–C2	28	21	46
C5–O5–C2–C3	–41	5	–38
O5–C2–C3–C4	37	–28	15
C2'–C3'–C4'–C5'	27	29	34
C3'–C4'–C5'–O5'	–11	–4	–7
C4'–C5'–O5'–C2'	–23	–19	–19
C5'–O5'–C2'–C3'	40	38	41
O5'–C2'–C3'–C4'	–41	–42	–46

^aFrom the X-ray structure.^bFrom molecular modeling studies.

the somewhat higher energy *BC*-2,4,7 conformations, respectively (Figure 2). In this nomenclature the numbers indicate the relative position of oxygen atoms if the ring is numbered clockwise commencing with position 1 at the boat apex, which is the right hand apex for compounds **2** and **3** in Figure 2.

In contrast to these examples and calculations the 1,3,6-trioxacane ring of **1** is in the twist-boat-chair (*TBC*) conformation (Figure 2). Calculations for unsubstituted cyclooctanes^[11] indicate that the twist-boat-chair is a higher energy conformation than the boat-chair. Anet^[8] places the twist-boat-chair in the same conformational family as the boat-chair with a relatively low energy pseudorotational pathway connecting the two conformations. Table 2 lists the torsion angles found in **1** together with the previously calculated^[11] values for an unsubstituted, cyclooctane ring in the *TBC* conformation and the values calculated by molecular modeling for **1** and the underivatized analog. The torsion angles for **1** parallel the calculated values with some distortion due to constraints imposed by substituents. The good agreement between the measured angles and those calculated indicate that the conformation is intrinsic rather than imposed by crystal packing forces. The relatively small differences between the calculated values for **1** and its underivatized analog indicates that the *TBC* con-

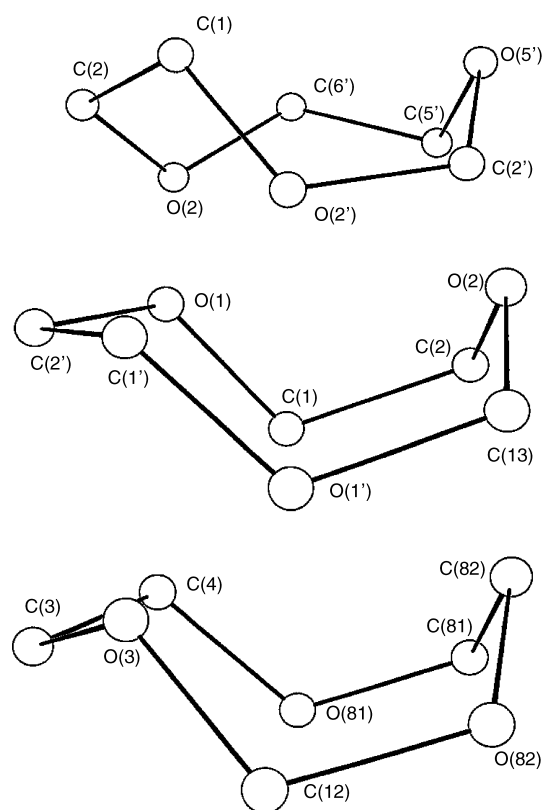

Figure 2. A comparison of the conformations of the eight-membered, trioxacane rings in **1** (top), **2**^[9] (middle) and **3**^[10] (bottom).



formation is likely also to be found in the underivatized sugar with H-bonding or steric interactions between acetyl groups having little influence.

The 1,2-linked furanose ring is in the E_2 conformation with O-5 axially disposed relative to the central eight-membered, trioxacane ring; the atoms C3, C4, C5 and O5 are planar to within ± 0.02 Å, and this plane makes a dihedral angle with the O5C2C3 plane of 38.7 degrees. The 2',6'-linked furanose ring is in the 2E conformation; O5'C5'C4'C3' are equiplanar with a fold angle to the O5'C2'C3' plane of 40.1 degrees. When these rings are compared with those calculated for both **1** and the underivatized analog, the conformation of the 2',6'-linked ring is conserved throughout (Table 3), suggesting this end of the molecule is held quite rigidly. The other end of the molecule is more flexible and a variety of conformations are observed in the 1,2-linked ring according to the method used, resulting in variation in the torsion angles shown in Table 3. In each case an envelope conformation is found but with E_2 for the X ray structure, 4E in modeled **1** and E_5 for the underivatized analog, respectively. However, the modeling studies suggest that the energy differences between these three conformations is only of the order of 1–3 kcal mol⁻¹, so it is not surprising that this varies. This greater flexibility and the change in conformation between **1** and its underivatized analog may account for the observation^[2] that the C-1 and C-6' pairs of protons are NMR equivalent in the underivatized analog but this equivalence is lost upon acetylation. It is possible that the bulkier acetyl groups restrict the flexibility.

On the basis of substituent interactions a conformation in which C-3 and C-4 are puckered is most likely for an unconstrained fructofuranose ring in an oligosaccharide,^[9] as well as in 1,2-linked furanose units in di-D-fructose dianhydrides.^[12] Drew et al.^[9] found that the fructofuranose ring in **2** exhibited an E_O conformation, which was noted as unusual. Although no reason could be ascertained to account for this, judgement was reserved with respect to the effect of the acetate groups as there were insufficient crystal structures of related acetates for comparison. French et al.^[13] have also found an E_O conformation for one of the rings of di(3-deoxy-D-glycero-pentulose) 1,2':2,1'-dianhydride.

The absolute configurations of C-2 (α) and C-2' (β) in **1**, which were originally assigned by NMR,^[11] are now confirmed.

The stability of di-D-fructose dianhydrides to thermal and acidic conditions has been noted by several authors.^[12] In a kinetic study^[2] of the formation and disappearance of di-D-fructose dianhydrides during thermal treatments of inulin, α -D-Fruf-1,2':2,6'- β -D-Fruf was found to form early but also to disappear much more rapidly than other species; this apparent instability was attributed to the size and shape of the central ring; the eight-membered, trioxacane ring in α -D-Fruf-1,2':2,6'- β -D-Fruf differs from the six-membered, dioxane ring of most other di-D-fructose dianhydrides. Eight-membered rings are of themselves less stable than six-membered rings (13.13 kcal mol⁻¹ total strain energy for cyclooctane in the *TBC* conformation compared with 1.08 kcal mol⁻¹ for cyclohexane in the chair conformation^[11]).

However, when oxygens are introduced both within and substituent to the ring, it is possible for extra stabilization to be derived from the anomeric effect. This effect has been shown to be the strongest conformational influence in di-D-fructopyranose dianhydrides that are 1,2':2,1'-linked.^[14] As a result of the anomeric effect, the central, 6-membered, dioxane ring of such compounds adopts a conformation that has O-5 and O-5' both axially disposed, that is a chair conformation if the anomeric centers of the

 **α -D-Fruf-1,2':2,6'- β -D-Fruf**

7

two fructose rings differ and a boat conformation if they are the same. At the same time the fructopyranose rings adopt chair conformations such that O-2 and O-2' are axially disposed. The anomeric effect also appears to operate in difructofuranose dianhydrides as crystal structures of a 1,2':2,1'-linked di-D-fructofuranose dianhydride^[15] and of a model compound^[13] showed similar behaviour. Where di-D-fructose dianhydrides are formed under conditions that permit equilibration, distribution of products has been explained in terms of these conformational effects.^[16]

In **1** there are two positions at which the anomeric effect might occur, that is two carbons each with two oxygens attached; these are C-2 and C-2'. The torsion angles about C-2' are 30 and 76 degrees where 60 degrees would indicate perfect geometry for n- σ^* overlap, to which the anomeric effect is attributed. The rigidity of the molecule at this position probably precludes the required conformation for n- σ^* overlap. The other possible position at which this effect may occur, around the spiro junction of 1,2-linked fructofuranose has torsion angles of 60 and 69 degrees. This end of the molecule has greater flexibility and can assume a variety of conformations. Examination of molecular models reveals that, were **1** to assume the putatively lower energy *BC* conformation, the torsion angles would be incorrect for n- σ^* overlap. It would appear that the *TBC* conformation is stabilized relative to the *BC* conformation by the operation of the anomeric effect; however, because of rigidity at the C-2' position, the molecule cannot benefit fully from the stabilizing influence of the anomeric effect. This taken in conjunction with the inherent higher energy of the eight-membered ring most likely accounts for the lack of thermal stability of α -D-Fruf-1,2':2,6'- β -D-Fruf.

SUPPLEMENTARY MATERIAL

Full crystallographic details for **1** have been submitted to the Cambridge Crystallographic Data Centre, (Accession No. CCDC 193546). Copies of this information may be obtained free of charge from The Director, CCDC, 12 Union Road, Cambridge, CB2 1EZ, UK (Tel.: 44-1223-336408, fax: 44-1223-336033; email:deposit@ccdc.cam.ac.uk or www:http://www.ccdc.cam.ac.uk).

ACKNOWLEDGMENTS

We thank Dr. Jan Wikaira, University of Canterbury, for collection of X-ray intensity data. We also thank Beverly Parker, University of Montana, for the preparation of α -D-fructofuranose- β -D-fructofuranose 1,2':2,6'-dianhydride.

REFERENCES

1. Matsuyama, T.; Tanaka, K.; Uchiyama, T. Isolation and identification of the *Aspergillus fumigatus* difructose dianhydride. *Agric. Biol. Chem.* **1991**, *55* (5), 1413–1414.
2. Christian, T.J.; Manley-Harris, M.; Field, R.J.; Parker, B.A. Kinetics of formation of



- di-D-fructose dianhydrides during thermal treatment of inulin. *J. Agric. Food Chem.* **2000**, *48*, 1823–1837.
- Sheldrick, G.M. *SHELX97—Programs for X-Ray Crystallography*; University of Göttingen, 1997.
 - Macromodel*; Schrödinger Inc.: Portland, USA, 1999.
 - IUPAC Nomenclature of carbohydrates. *Adv. Carbohydr. Chem. Biochem.* **1997**, *52*, 43–171.
 - Burkert, U. The conformations of oxacyclooctanes. *Z. Naturforsch.* **1980**, *35b*, 1479–1481.
 - Dale, J.; Ekeland, T.; Krane, J. Conformational Studies of oxygen-heterocyclic eight-membered rings. *J. Am. Chem. Soc.* **1972**, *94* (4), 1389–1390.
 - Anet, F.A.L. Dynamics of eight-membered rings in the cyclooctane class. *Fortschr. Chem. Forsch.* **1974**, *45*, 169–220.
 - Drew, M.G.B.; Lindseth, H.; Khan, R. Crystal and molecular structure of 1',2:4,6-di-*O*-isopropylidenesucrose tetraacetate: a unique example of a D-fructofuranosyl ring in a sucrose derivative puckered at oxygen. *Carbohydr. Res.* **1979**, *71*, 35–42.
 - Thiem, J.; Klaska, K.H.; Jarchow, O. Synthesis, crystal structure, and conformation of cellobiosides containing intersaccharide alkylidene bridges as part of tri-oxacyclooctane or -nonane ring systems. *J. Chem. Res., Synop.* **1980**, *6*, 190–191.
 - Hendrickson, J.B. Molecular geometry. V. Evaluation of functions and conformations of medium rings. *J. Am. Chem. Soc.* **1967**, *89* (26), 7036–7043.
 - Manley-Harris, M.; Richards, G.N. Dihexulose dianhydrides. *Adv. Carbohydr. Chem. Biochem.* **1997**, *52*, 207–266, and references cited therein.
 - French, A.D.; Jeffrey, G.A.; Pfeffer, P.; Dudley, R.L.; Yeon, Y.; Nitsch, E. An NMR, x-ray crystal structure, and molecular mechanics study of di-(3-deoxy-D-glycero-pentulose) 1,2':2,1'-dianhydride. *Carbohydr. Res.* **1994**, *260*, 1–15.
 - Bock, K.; Pedersen, C.; Defaye, J.; Gabelle, A. Steric and electronic effects in the formation of dihexulose dianhydrides. Reaction of racemic sorbose in anhydrous hydrogen fluoride and a facile synthesis of D-sorbose. *Carbohydr. Res.* **1991**, *216*, 141–148.
 - Ashraf Shalaby, M.; Fronczek, F.R.; Younathan, E.S. The configuration and conformation of di-D-fructose anhydride I. The crystal and molecular structure of 3,4,3',4'-tetra-*O*-acetyl-6,6'-di(triphenylmethyl)-di-D-fructose dianhydride I. *Carbohydr. Res.* **1994**, *265*, 207–214.
 - Defaye, J.; García Fernández, J.M. Selective protonic activation of isomeric glycosylfructoses with pyridinium poly(hydrogen fluoride) and synthesis of spirodioxanyl oligosaccharides. *Carbohydr. Res.* **1992**, *237*, 223–247.

Received May 10, 2002

Accepted September 16, 2002